

winterhalter

Spare parts list GS 202 - GS 402

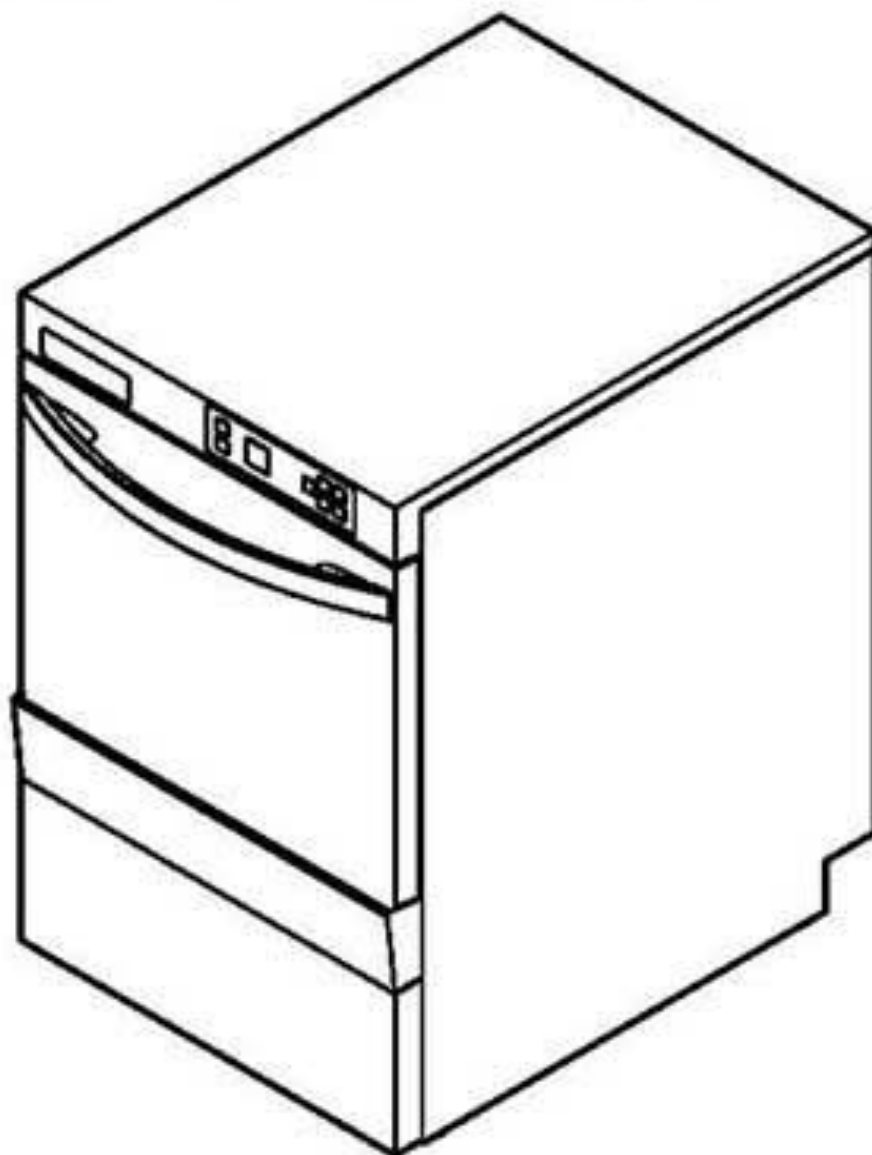

Contents

Water inlet		Page 1 - 2
Water softener		Page 3 - 4
Water drain, Mediamat Cyclo		Page 5 - 6
Wash pump		Page 7 - 8
Bottom washing/rinsing system		Page 9 - 10
Rinse system top	GS 202	Page 11 - 12
Top washing/rinsing system	GS 402	Page 13 - 14
Pressure boiler		Page 15 - 16
Pressure-independent boiler		Page 17 - 20
Dosage		Page 21 - 22
Chassis, container and panelling		Page 23 - 24
Door		Page 25 - 26
Electric parts		Page 27 - 30

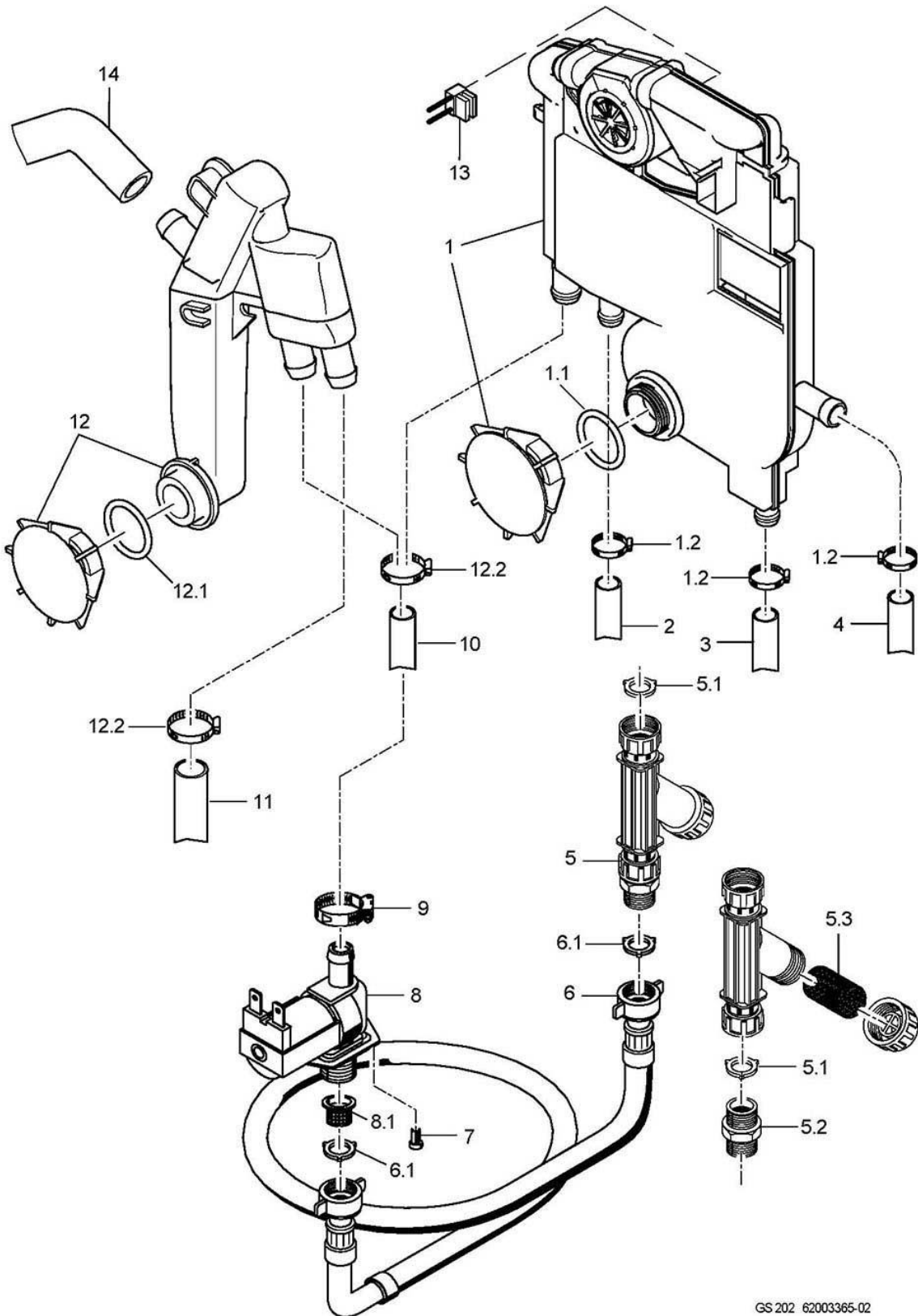

GS 202 62003365-02

GS 202 - GS 402

Water inlet

Item.	Designation	Parts no.:	Pc.	Notes
1	Set of WSE without impeller counter	60003511		For machines without integrated water softener in the UK and Australia only
1	WSE with impeller counter kit	60003512		for machines with built-in water softener
1.1	O-ring; 24 X 3,0	27 07 087		without built-in water softener
1.2	Hose clamp; D12-22 X 9	28 02 105	4	
2	Hose; DN10 X 2,0	40 01 050		785 mm; Metre item; Regeneration water softener
3	Hose; DN10 X 2,0	40 01 050		680mm; to built-in water softener
3	Shaped hose; DN10 X DN12 X 3,5	62003090		to pressure-independent boiler
4	Shaped hose; DN12,5 X 3,5	62003105		Deaeration; Pressure-independent boiler
5	Dirt trap; 150 µM	80002153		
5.1	Gasket; D16 X D24 X 3,0	80002241	3	
5.2	Double nipple; G 3/4" X 40; SW30	80002167		
5.3	Strainer; D27 X 67 X 150µM	80002728		
6	Water supply hose; DN13 X 3,5; 2500	40 02 060		
6	Water supply hose; DN13 X 3,5; 1500	40 02 045		
6.1	Gasket; D16 X D24 X 3,0	80002241	2	
7	Countersunk screw; M4 X 8	20 10 309	2	
8.1	Solenoid valve filter	31 06 186		
8	Solenoid valve flow restrictor 15l; 230-240V 50/60HZ RAST5	31 06 214		Pressure boiler
8	Solenoid valve flow restrictor 5l; 230-240V 50/60HZ RAST5	31 06 215		Pressure-independent boiler
8	Solenoid valve flow restrictor 15l; 200-208V 50/60HZ RAST5	31 06 212		Pressure boiler
8	Solenoid valve flow restrictor 5l; 200-208V 50/60HZ RAST5	31 06 213		Pressure-independent boiler
9	Hose clamp; D12-22 X 9	28 02 105		
10	Industrial hose; DN13 X 3,5	40 02 035		515 mm; "By-the-metre" goods
11	Hose; DN12,5 X 3,5; 520	62003092		to machine no.: 830 280
11	Moulded hose; DN12 X DN13,5 X 3,0	62003665		From machine no.: 830 281
12	Reverse flow inhibitor kit	60003846		to machine no.: 806 976 ; order too 515mm x 4002029 + 62003092
12	Reverse flow inhibitor kit	60003846		From machine no.: 806 977
12	Reverse flow inhibitor kit	60003846		From machine no.: 830 281; For machines without integrated water softener, not for UK and Australia
12	Separate check valve set	62003680		to machine no.: 830 280; Replacement for WSE set (pos. 1) for machines without integrated water softener, not for UK and Australia
12.1	O-ring; 24 X 3,0	27 07 087		
12.2	Hose clamp; D12-22 X 9	28 02 105	4	
13	Cable WMZ; 2 X 0,34QMM	60003179		Pressure-independent boiler and water softener installed
14	Moulded hose; DN13,5 X 3,0	62003666		

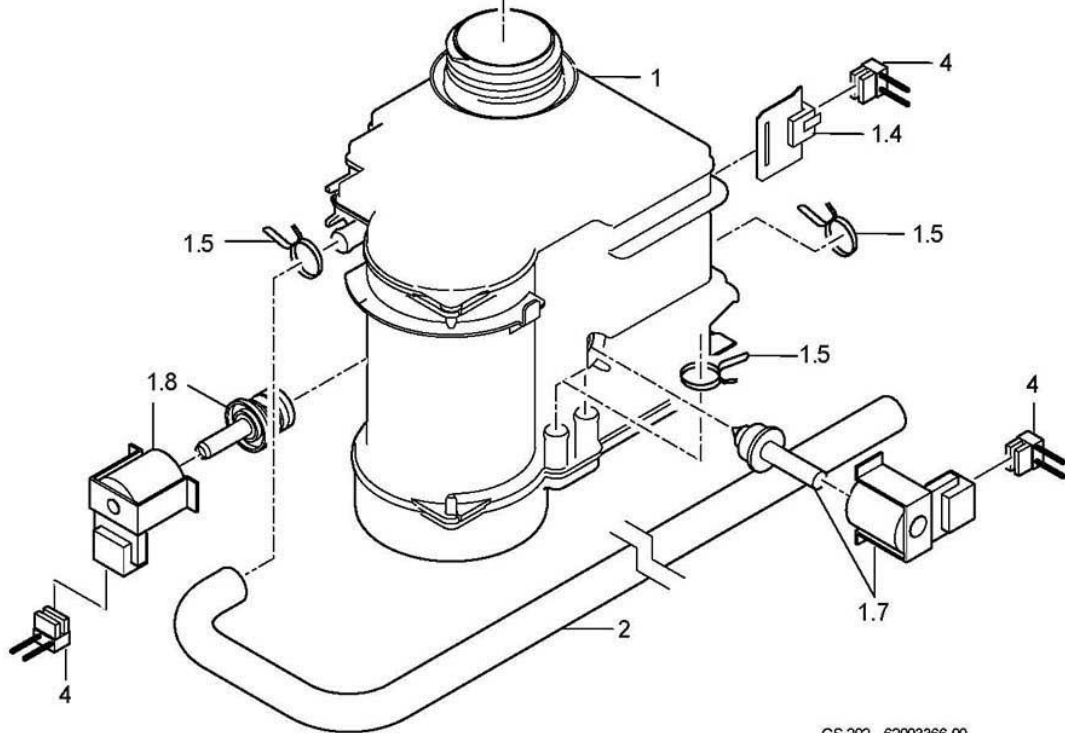
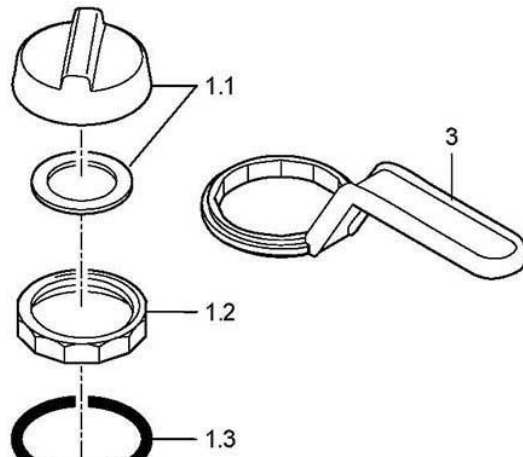
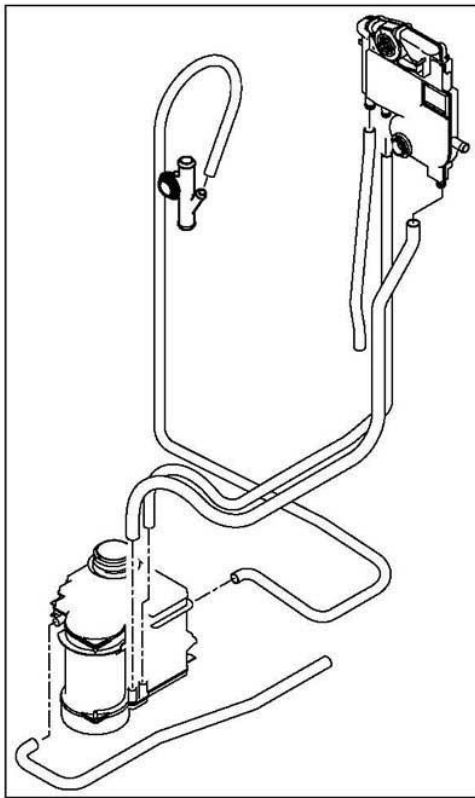

GS 202 62003366-00

GS 202 - GS 402

Water softener

Item.	Designation	Parts no.:	Pc.	Notes
1	Water softener kit; 220-240V; 50/60HZ	83000420		
1	Water softener kit; 200-210V; 50/60HZ	83000421		
1.1	Cover, complete, with seal	83000407		
1.2	Lock nut; S54 X 4; D56	60003001		
1.3	O-ring; 54 X 5	27 07 065		
1.4	Dry reed contact lack of salt	83000408		
1.5	Wire hose clamp; D14,4 X 15,1	28 02 344	4	
1.7	Repair kit regeneration valve; 220-240V,50/60HZ	83000402		
1.7	Repair kit regeneration valve; 200-210V,50/60HZ	83000463		
1.8	Repair kit reversing valve; 220-240V,50/60HZ	83000460		
1.8	Repair kit reversing valve; 200-210V,50/60HZ	83000467		
2	Shaped hose; DN10 X DN12,5 X 2,0	62003098		
3	Double hex ring spanner; SW61,5	60003376		
4	Wiring loom; Water softener	60003185		
o.P.	Filling funnel	35 02 013		

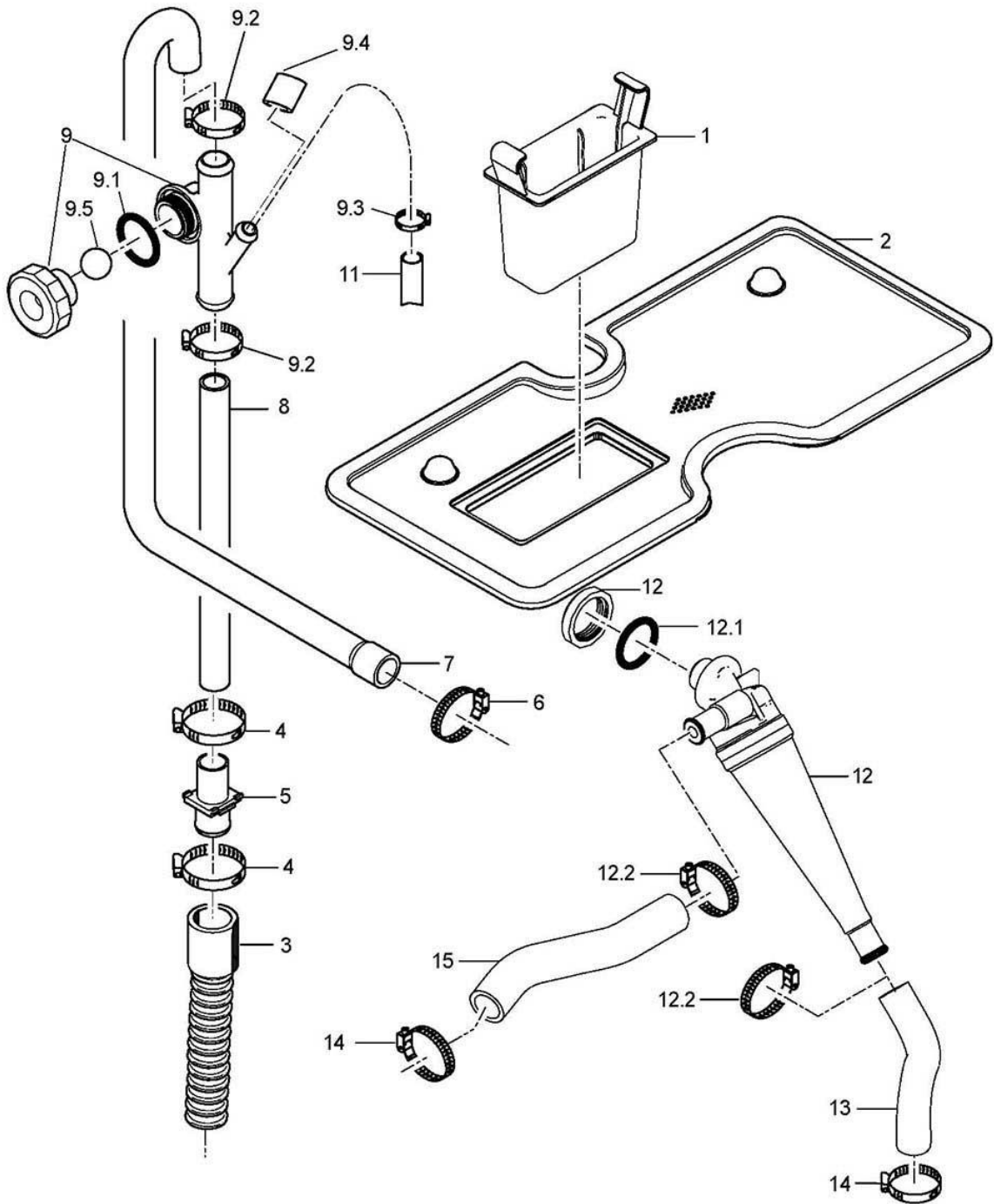

GS 402 62008543-01

GS 202 - GS 402

Water drain, Mediamat Cyclo

Item.	Designation	Parts no.:	Pc.	Notes
1	Filter cartridge cpl.	60003039		
2	Flat filter; 0,8 X 201 X 436	62003614		
3	Drain hose; 1500 LG	60003738		
4	Hose clamp; D20-30 X 12	28 02 109		
5	Double nipple; D21,80 X 49; D19	60003399		
6	Hose clamp; D20-30 X 12	28 02 109		
7	Shaped hose; DN18 X DN22 X 3,5	62003108		
8	Reinforced hose; DN19 X 2,5	40 01 046		495mm; "By-the-metre" goods
9	Deaeration kit	60003514		
9.1	O-ring; 24 X 3,0	27 07 087		
9.2	Hose clamp; D20-30 X 12	28 02 109	2	
9.3	Hose clamp; D10-16 X 9	28 02 307		
9.4	Round cap; D11 X 20	35 03 029		
9.5	Ball; D14	28 01 508		
11	Hose; DN10 X 2,0	40 01 050		900 mm; "By-the-metre" goods
12	Mediamat Cyclo kit	60003513		GS 402
12.1	O-ring; 17 X 3	27 07 068		
12.2	Hose clamp; D12-22 X 9	28 02 105	2	
13	Shaped hose; DN12,5 X 2,0; 115	62003409		GS 402
14	Hose clamp; D12-22 X 9	28 02 105		GS 402
15	Shaped hose; DN12 X 3,5; 141	60003713		GS 402

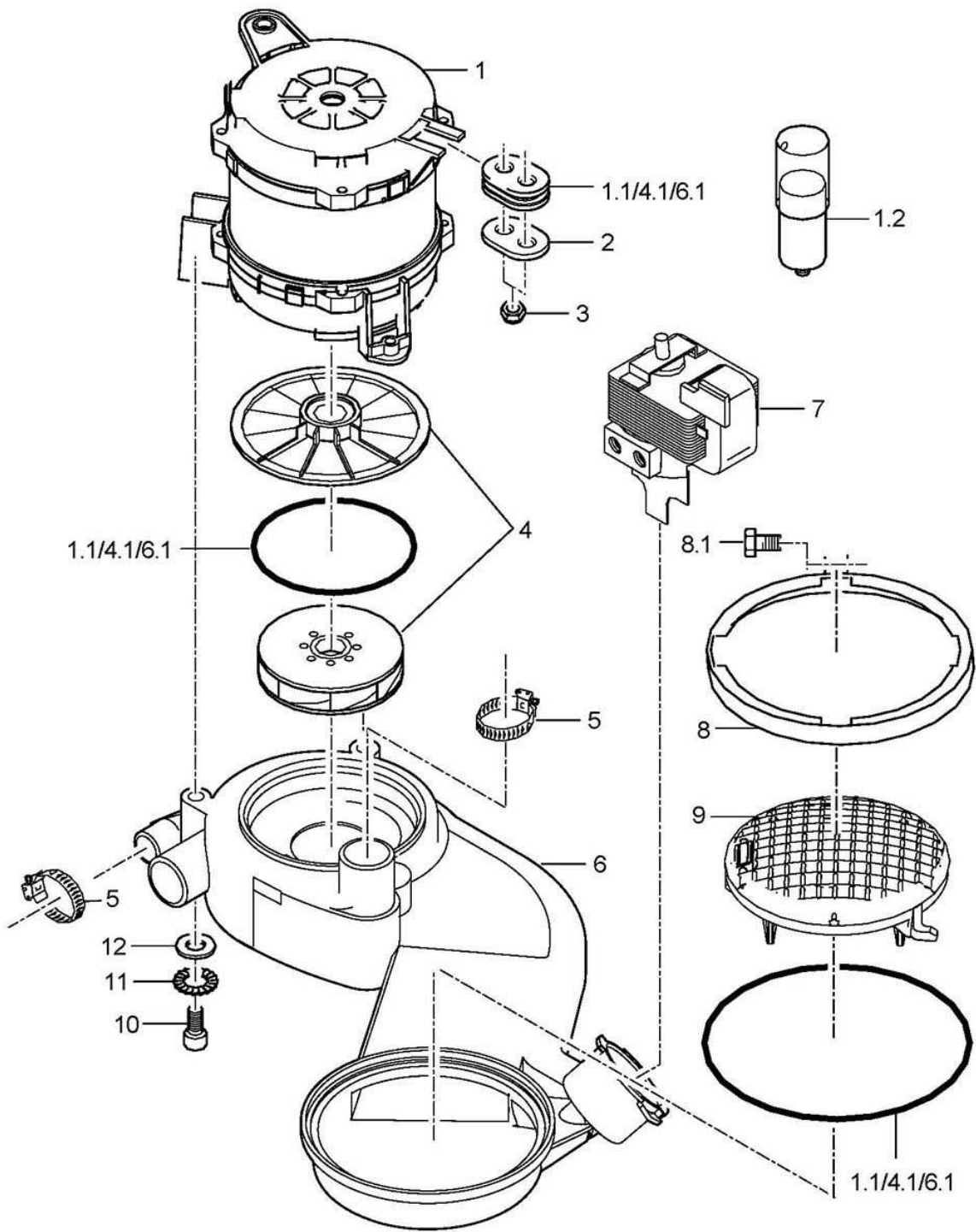

GS 202-402 62003544-00

GS 202 - GS 402

Wash pump

Item.	Designation	Parts no.:	Pc.	Notes
1	Pump motor kit; 230-240V/50-60HZ	60003595		we recommend ordering the set of pump running wheels, as well, when the motor is replaced
1	Pump motor kit; 200V/50-60HZ	60003596		we recommend ordering the set of pump running wheels, as well, when the motor is replaced
1.1	Sealing for pump system kit	60003591		
1.2	Capacitor; 10YF 400V; D35 X 80	31 13 120		
1.2	Capacitor; 12YF 400V;	31 13 122		Japan
2	Spacer washer; 1,25 X 18 X 28	60003298	2	
3	Hexagonal nut; M5 SELBSTSICHERND	21 05 302	4	
4	Impeller with sealings kit; D75	60003593		50 Hz
4	Impeller with sealings kit; D66	60003594		60 Hz
4.1	Sealing for pump system kit	60003591		
5	Hose clamp; D32-52 X 12	28 02 110	2	GS 402
6	Collector kit; WASCHSYSTEM UNTEN	60003597		
6	Collector kit; WASCHSYSTEM UNT.+OBEN	60003620		GS 402
6.1	Sealing for pump system kit	60003591		
7	Drain pump; 220-240V/50HZ	31 02 480		
7	Drain pump; 200V/50HZ;220-240V/60H	31 02 493		
7	Drain pump; 200V/60HZ	31 02 495		
8	Pump clip	62003437		
8.1	Hexagon screw; M5 X 40; A70	20 01 329		
9	Filter insert	60003259		
10	Cylinder head screw; M5 X 20; 8,8	20 09 337	3	
11	Serrated lock washer; A-5,3	22 02 316	3	
12	Washer; D5,3 X D10 X 1,0	22 01 300	3	
o.P.	Assembly device, complete	60003450		Tool for exchanging drain pot

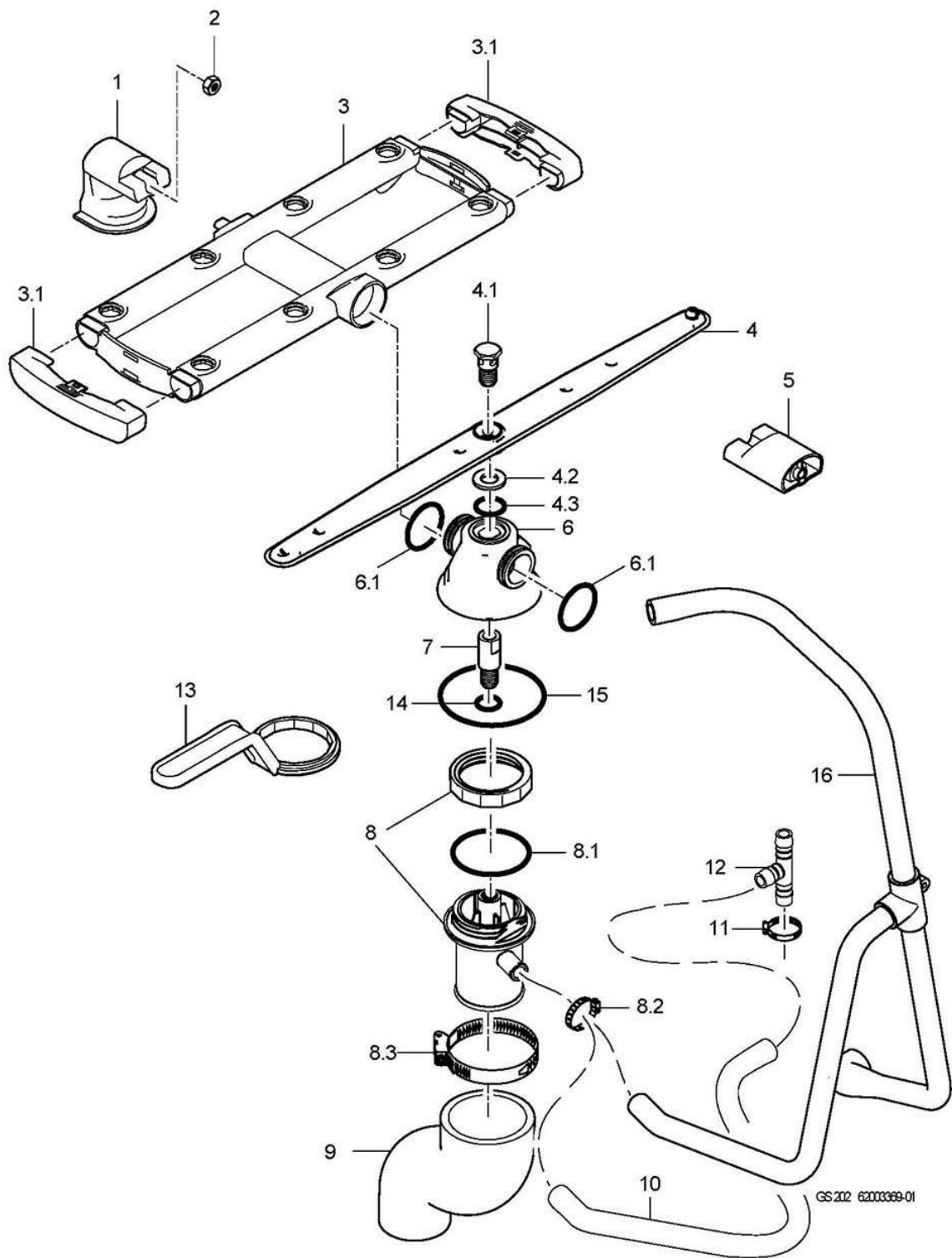

GS 202 - GS 402

Bottom washing/rinsing system

Item.	Designation	Parts no.:	Pc.	Notes
1	Wash unit support; 70,70 LG	62003287		
2	Ratchet nut; M5	21 01 310	2	
3	Wash unit cpl.; 8 DÜSEN; 387 LG	62003539	2	
3.1	End piece; 128 LG	62003538		
4	Rinsing wash arm set; 6 DÜSEN	62003347		
4.1	Revolving arm screw; M12 X 30; SW19	60003045		no longer deliverable; up to mach. no.: 812 867 replaced by 62003347
4.1	Rotary arm screw; M12 X 36; SW19	60004123		From machine no.: 812 868
4.2	Washer; D12,5 X D24 X 2,5	60003386		
4.3	O-ring; 10 X 2,5	27 07 030		
5	Wash unit support; 33,67 LG	62003020	1	
6	Distributor top kit	62003406		GS 202
6	Distributor top kit	60003516		GS 402
6.1	Seal ring; D29,3 X D33,8 X 2,5	60004276	2	
7	Revolving rinse arm spindle; D16 X 44,5; M12	60003043		
8	Distributor bottom kit	62003345		GS 202
8	Distributor bottom kit	62003534		GS 402
8.1	O-ring; 56 X 3,0	27 07 086		
8.2	Hose clamp; D12-22 X 9	28 02 105		
8.3	Hose clamp; D47-67 X 12	28 02 115		
9	Reducing hose; DN34 X DN48; 110	62002984		
10	Industrial hose; DN13 X 3,5	40 02 035		410mm; Metre item; pressure boiler
11	Hose clamp; D12-22 X 9	28 02 105		
12	Hose T-connecting piece; D15 X D15 X D15	70010598		Pressure boiler
13	Double hex ring spanner; SW61,5	60003376		
14	O-ring; 66 X 2,5	27 07 011		No longer has to be installed
15	O-ring; 10 X 1	27 07 054		up to 07/2002
16	Rinse manifold	62003600		Pressure-independent boiler

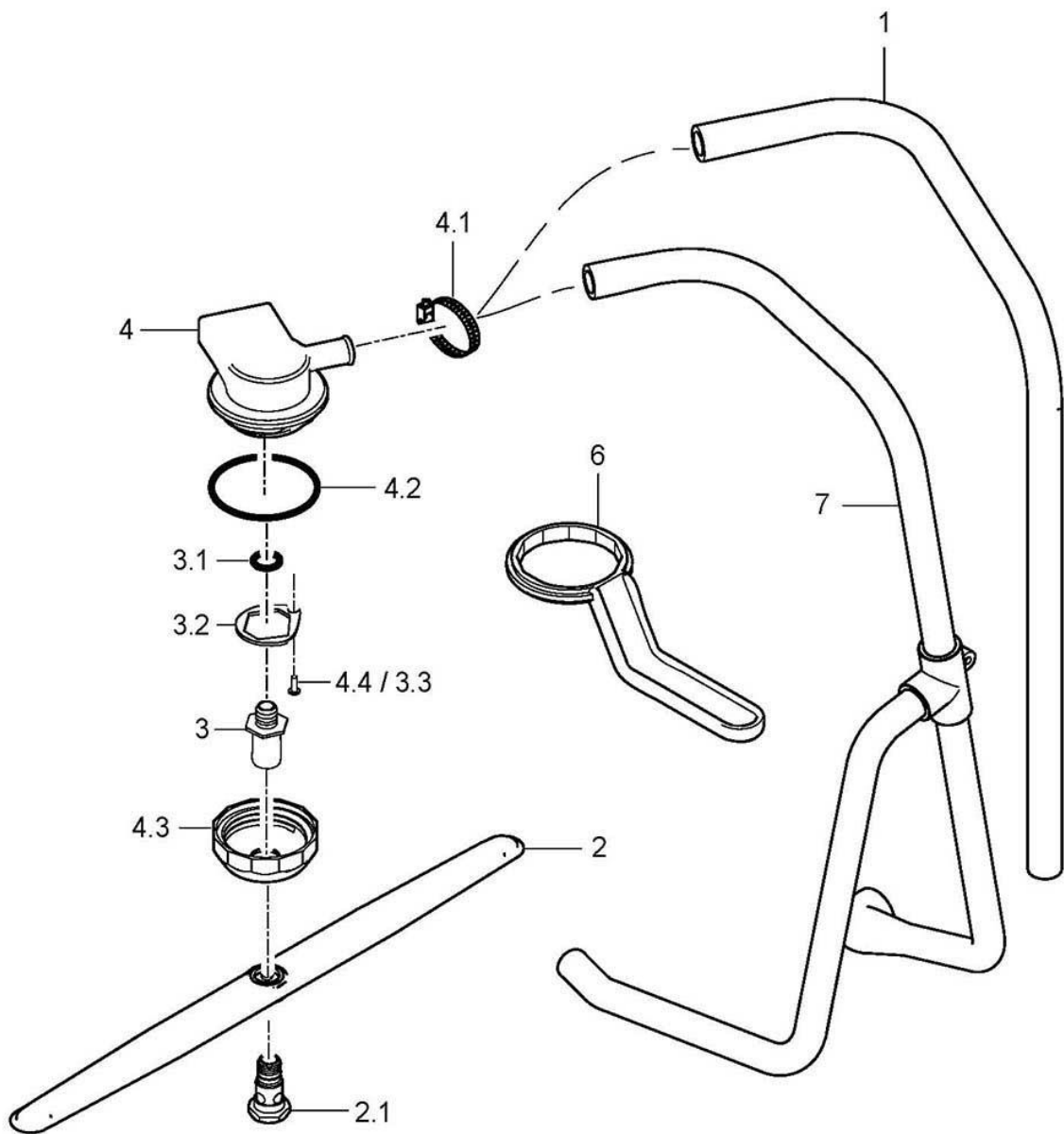

GS 202 - GS 402

Rinse system top GS 202

Item.	Designation	Parts no.:	Pc.	Notes
1	Shaped hose; DN12,5 X DN14 X 3,5	62003101		Pressure boiler
2	Rinsing wash arm set; 6 DÜSEN	62003347		
2.1	Revolving arm screw, M12 X 30; SW19	60003045		no longer deliverable; up to mach. no.: 812 867 replaced by 62003347
2.1	Rotary arm screw, M12 X 36; SW19	60004123		From machine no.: 812 868
3	Revolving rinse arm spindle kit	60003617		
3.1	O-ring; 10 X 2,5	27 07 030		
3.2	Washer; 1,5 X 28 X 32,3	61006076		
3.3	Sheet metal screw; ST 3,5 X 9,5	20 20 305		
4	Set of water inlets top	62003346		
4.1	Hose clamp; D12-22 X 9	28 02 105		
4.2	O-ring; 56 X 3,0	27 07 086		
4.3	Lock nut; S54 X 4; D57	62003024		
4.4	Sheet metal screw; ST 3,5 X 9,5	20 20 305		
6	Double hex ring spanner; SW61,5	60003376		
7	Rinse manifold	62003600		Pressure-independent boiler

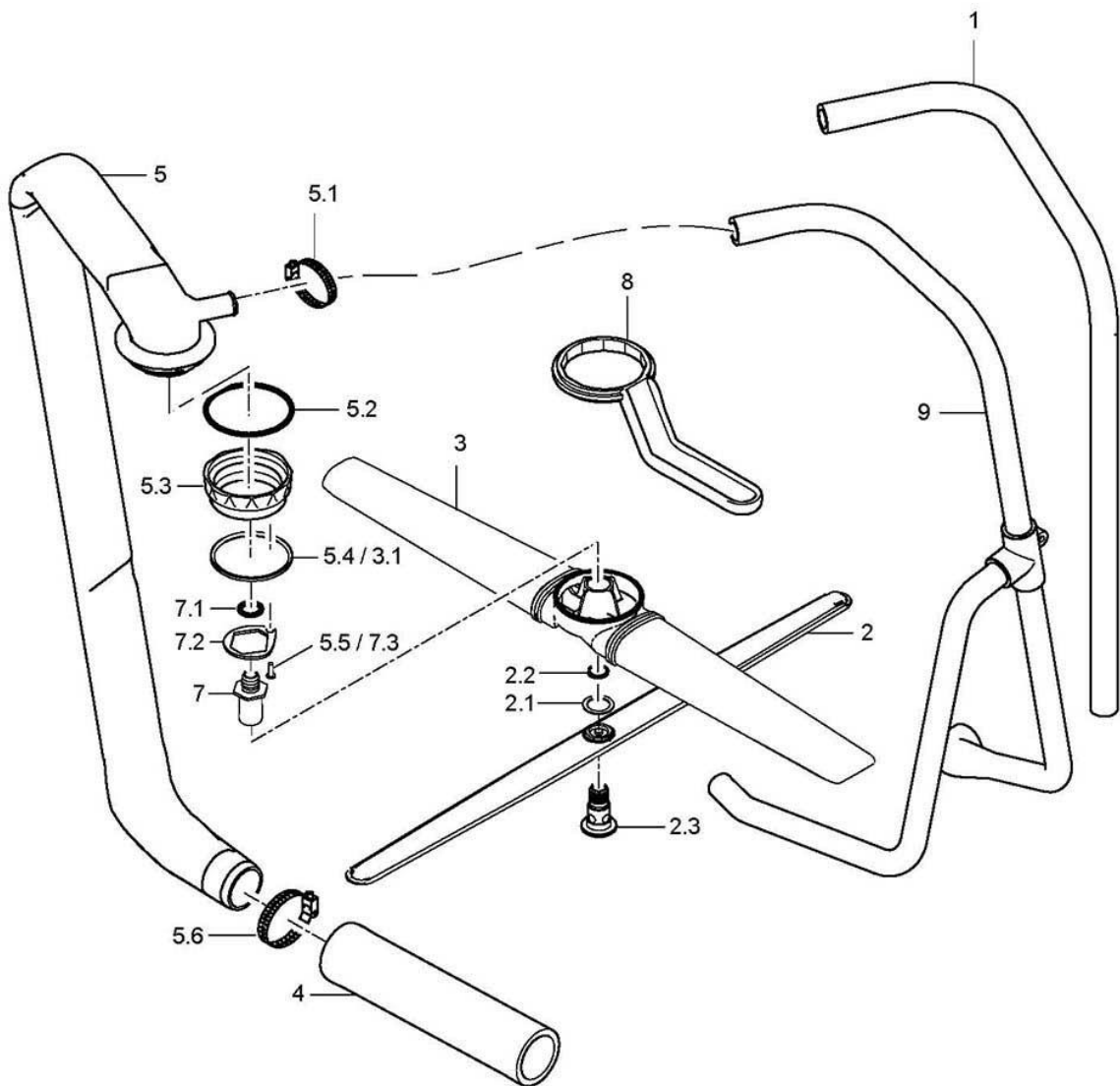

GS 202 62003530-01

GS 202 - GS 402

Top washing/rinsing system GS 402

Item.	Designation	Parts no.:	Pc.	Notes
1	Shaped hose; DN12,5 X DN14 X 3,5	62003101		Pressure boiler
2	Rinsing wash arm set; 6 DÜSEN	62003347		
2.1	Washer; D14,10 X D20 X 1,0	60003487		
2.2	Locking ring; D12 X 0,8	60003023		
2.3	Revolving arm screw; M12 X 33,9; D25	60003877		no longer deliverable; up to mach. no.: 812 867 replaced by 62003347
2.3	Rotary arm screw; M12 X 34,9; D35	60004125		From machine no.: 812 868
3	Set of rotary arms washing	62003531		
3.1	Seal ring; D53,4 X D57,8 X 2,0	60003021		
4	Hose; DN33 X 4,0; 225	60004843		adapt
5	Washing distributor top kit	62003532		
5.1	Hose clamp; D12-22 X 9	28 02 105		
5.2	O-ring; 56 X 3,0	27 07 086		
5.3	Lock nut; S54 X 4; D57	60003005		
5.4	Seal ring; D53,4 X D57,8 X 2,0	60003021		
5.5	Sheet metal screw; ST 3,5 X 9,5	20 20 305		
5.6	Hose clamp; D32-52 X 12	28 02 110		
7	Revolving rinse arm spindle kit	60003616		
7.1	O-ring; 10 X 2,0	27 07 080		
7.2	Washer; 1,5 X 28 X 32,3	61006076		
7.3	Sheet metal screw; ST 3,5 X 9,5	20 20 305		
8	Double hex ring spanner; SW61,5	60003376		
9	Rinse manifold	62003600		Pressure-independent boiler

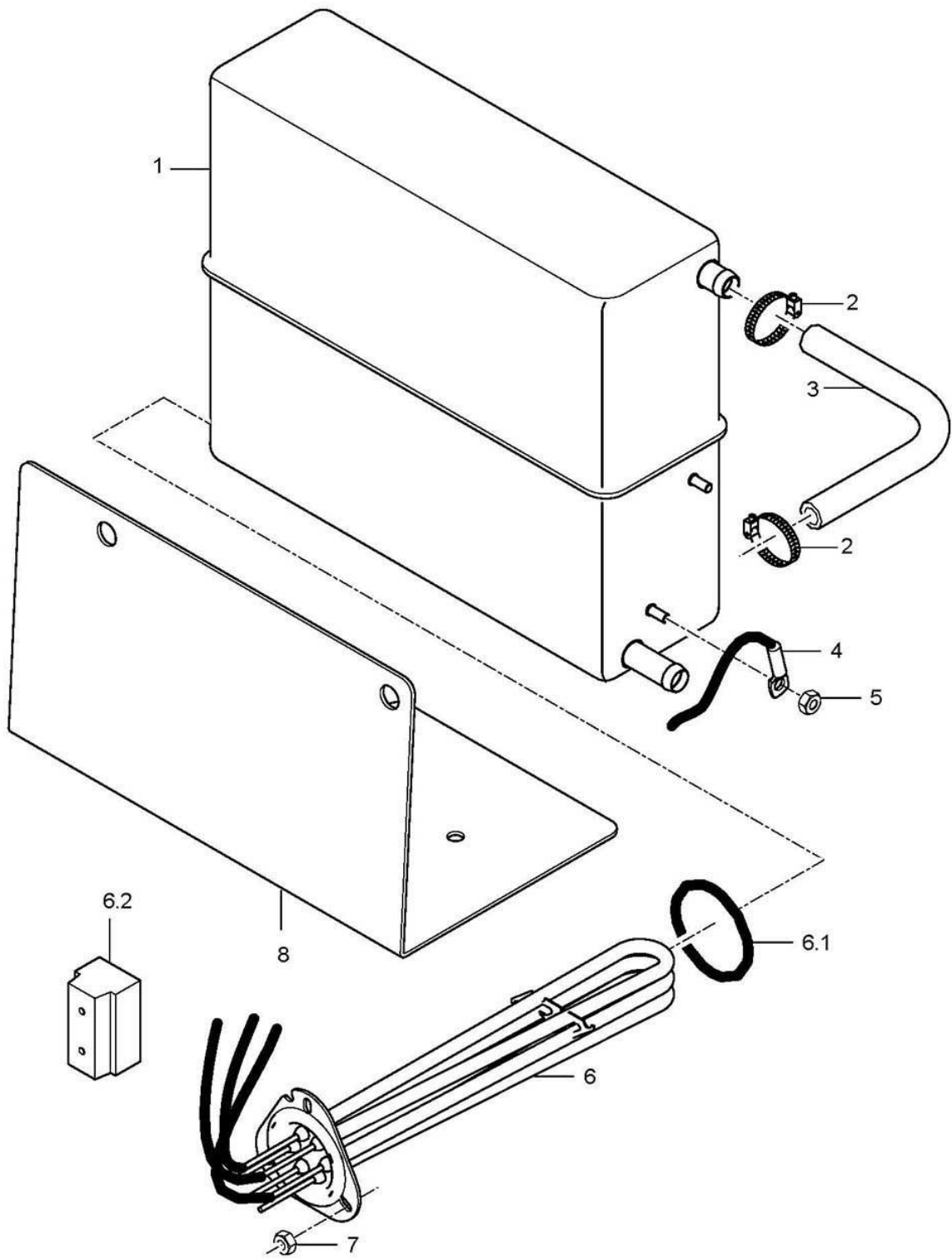

GS 202 62003371-00

GS 202 - GS 402

Pressure boiler

Item.	Designation	Parts no.:	Pc.	Notes
1	Pressure boiler cpl.	62003255		
2	Hose clamp; D12-22 X 9	28 02 105		
3	Industrial hose; DN13 X 3,5	40 02 035		225mm; "By-the-metre" goods
4	Thermal sensor kit 1700mm	80003804		with heat-conducting foil
5	Ratchet nut; M5	21 01 310	2	
6	Heater with fuse; 5.0kW; 3 X 380-420V	60003598		Rotary current (star connection)
6	Heater with fuse; 5.0kW; 3 X 240V DREIECK	60003599		Rotary current (delta connection)
6	Heater with fuse; 5.0kW; 3 X 200-208V STERN	60003600		
6	Heater with fuse; 5.0kW; 3 X 380-420V STERN	60003601		Rotary current (Australia)
6	Heater with fuse; 5.0kW; 3 X 440-460V STERN	60003833		
6	Heater with fuse; 3.5kW; 3 X 400V STERN	60003602		Rotary current (fuse protection 10A)
6	Heater with fuse; 4.0kW; 1 X 220-240V	60003604		Alternating current (fuse protection 25A; UK)
6	Heater with fuse; 2.6kW; 1 X 220-240V	60003605		Alternating current (fuse protection 16A)
6	Heater with fuse; 2.6kW; 1 X 240V	60003606		Alternating current (fuse protection 16A; Australia)
6	Heater with fuse; 2.6kW; 1 X 208V	60003607		Alternating current (fuse protection 20A; Japan, USA)
6	Heater with fuse; 1.8kW; 1 X 220-240V	60003610		Alternating current (fuse protection 13A; UK)
6	Heater with fuse; 1.1kW; 1 X 200V	60003608		Alternating current (Japan)
6.1	O-ring; 46 X 6,0	27 07 085		
6.2	Appliance terminal G10/4; 4-POLIG; 10QMM	31 09 227		
7	Hexagonal nut; M5	21 01 203	3	
8	Support; 1,5 X 180 X 206,8	62003290		

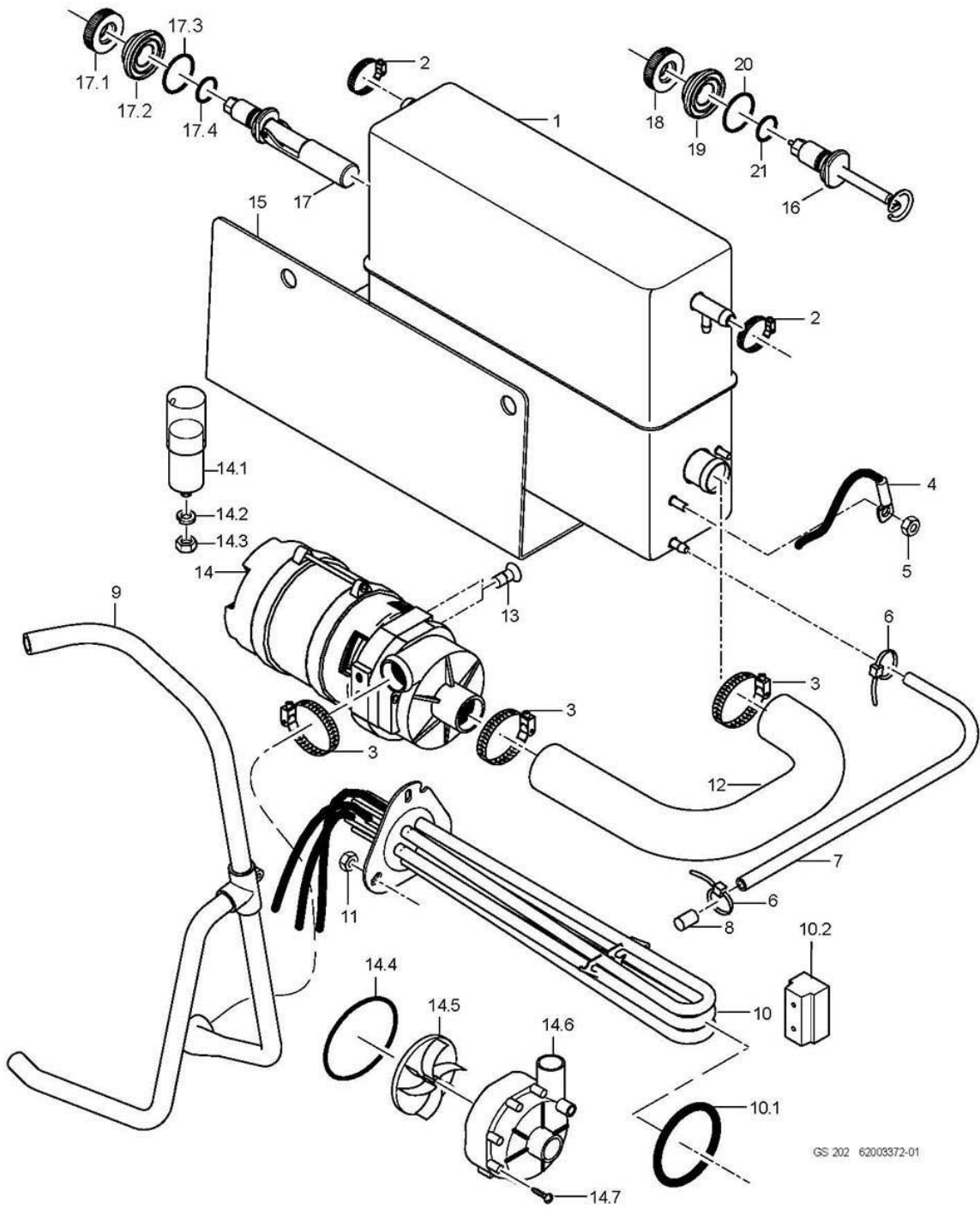

GS 202 62003372-01

GS 202 - GS 402

Pressure-independent boiler

Item.	Designation	Parts no.:	Pc.	Notes
1	Pressure-independent boiler	62002941		
2	Hose clamp; D12-22 X 9	28 02 105		
3	Hose clamp; D24-36 X 12	28 02 111		
4	Thermal sensor kit 1700mm	80003804		with heat-conducting foil
5	Ratchet nut; M5	21 01 310	2	
6	Cable tie; 100 X 2,5	31 20 175		
7	Hose; DN5 X 1,5	40 01 024		700 mm; "By-the-metre" goods
8	Bolt; D6 X 30	70200383		
9	Rinse manifold	62003600		
10	Heater with fuse; 5.0kW; 3 X 380-420V	60003598		Rotary current (star connection)
10	Heater with fuse; 5.0kW; 3 X 240V DREIECK	60003599		Rotary current (delta connection)
10	Heater with fuse; 5.0kW; 3 X 200-208V STERN	60003600		
10	Heater with fuse; 5.0kW; 3 X 380-420V STERN	60003601		Rotary current (Australia)
10	Heater with fuse; 5.0kW; 3 X 440-460V STERN	60003833		
10	Heater with fuse; 3.5kW; 3 X 400V STERN	60003602		Rotary current (fuse protection 10A)
10	Heater with fuse; 4.0kW; 1 X 220-240V	60003604		Alternating current (fuse protection 25A; UK)
10	Heater with fuse; 2.6kW; 1 X 220-240V	60003605		Alternating current (fuse protection 16A)
10	Heater with fuse; 2.6kW; 1 X 240V	60003606		Alternating current (fuse protection 16A; Australia)
10	Heater with fuse; 2.6kW; 1 X 208V	60003607		Alternating current (fuse protection 20A; Japan, USA)
10	Heater with fuse; 1.8kW; 1 X 220-240V	60003610		Alternating current (fuse protection 13A; UK)
10	Heater with fuse; 1.1kW; 1 X 200V	60003608		Alternating current (Japan)
10.1	O-ring; 46 X 6,0	27 07 085		
10.2	Appliance terminal G10/4; 4-POLIG; 10QMM	31 09 227		
11	Hexagonal nut; M5	21 01 203	3	
12	Shaped hose; DN26 X 3,5	62003000		
13	Countersunk screw; M6 X 16	20 12 319	2	
14	Pump 0.14kW 3/3; 220V/240V/1/50HZ	31 02 561		Repair recommended only for pump housings with 7 screws
14	Pump 0.27kW 3/3; 220V/240V/1/60HZ	31 02 461		Repair recommended only for pump housings with 7 screws
14	Pump 0.27kW 3/3; 200V/1/50HZ	31 02 462		Repair recommended only for pump housings with 7 screws
14	Pump 0.27kW 3/3; 200V/1/60HZ	31 02 463		Repair recommended only for pump housings with 7 screws
14.1	Capacitor; 4 MIKRO F / 400V	31 13 171		Pump 0,14kW
14.1	Capacitor; 5 MIKRO F	31 13 099		Pump 0,27kW
14.2	Spring washer; B8	23 03 301		
14.3	Hexagonal nut; M8	21 01 305		
14.4	Cord; D=78 X 3; SHOR 50-55;	40 04 023		
14.5	Pump impeller; FÜR UP60/UP30 MIT 50HZ	31 02 466		50 Hz
14.5	Pump impeller, installed; FÜR UP60 MIT 60HZ	31 02 587		60 Hz
14.6	Pump housing; D=80,5MM	31 02 519		
14.7	Screw for pump housing	31 01 118	7	

For missing items, see next page

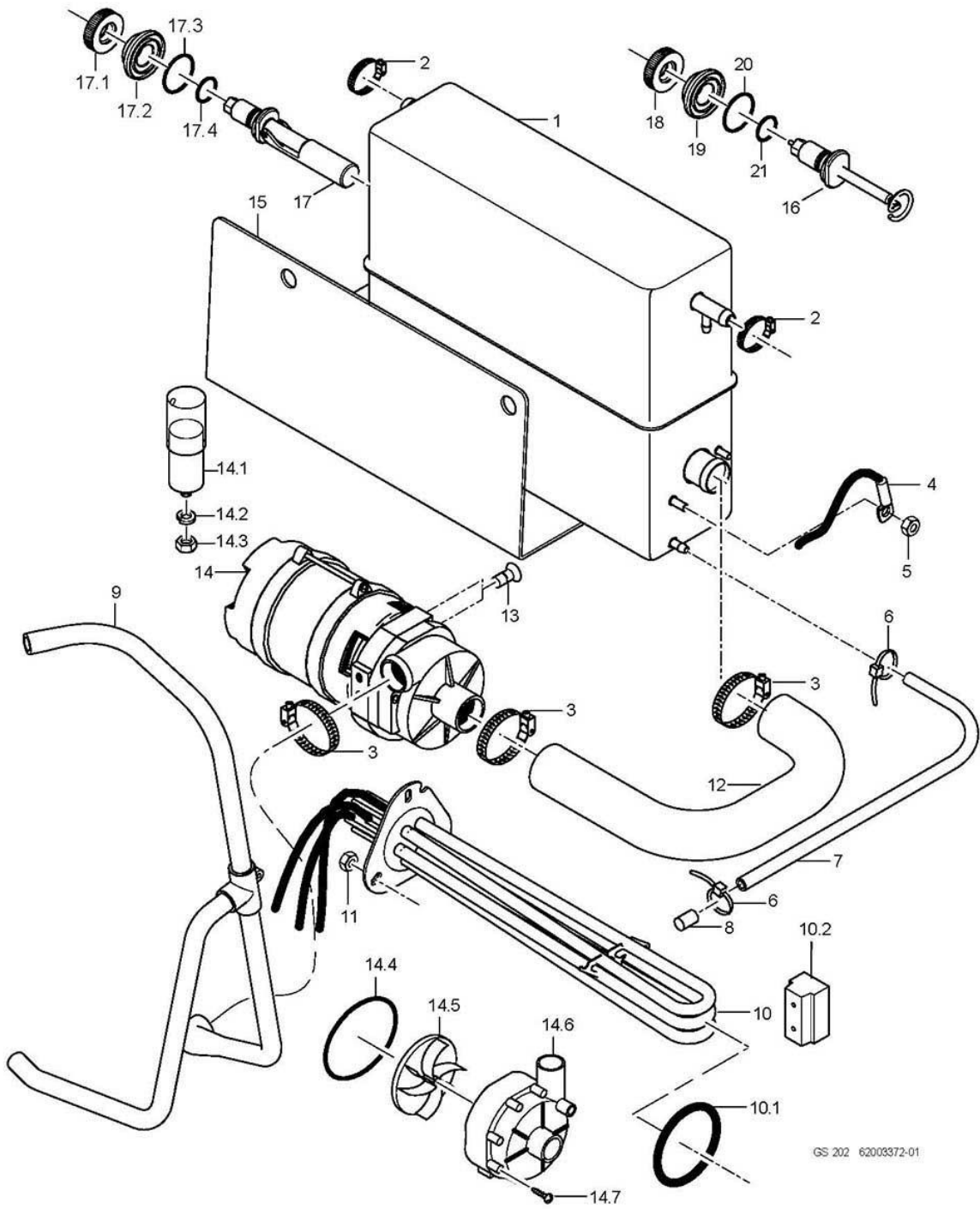

GS 202 62003372-01

GS 202 - GS 402

Pressure-independent boiler

Item.	Designation	Parts no.:	Pc.	Notes
15	Bracket; 1,5 X 182,7 X 185	62003144		
16	Floating switch installation set	55 28 255		Replacement for: 5528292 (Built-in electrode)
16.1	Nut; M14 X 2, D26,8 X 8	60003989		
16.2	Ring; D14,3 X D32 X 11	60003872		
16.3	O-ring; 23 X 3,5	27 07 093		
16.4	O-ring; 11,11 X 1,78	27 07 079		
17	Floating switch installation set	55 28 255		From machine no.: 821 128
17.1	Nut; M14 X 2, D26,8 X 8	60003989		
17.2	Ring; D14,3 X D32 X 11	60003872		
17.3	O-ring; 24 X 3,0	27 07 087		
17.4	O-ring; 11,11 X 1,78	27 07 079		
18	Nut; M14 X 2, D26,8 X 8	60003989		
19	Ring; D14,3 X D32 X 11	60003872		
20	O-ring; 24 X 3,0	27 07 087		
21	O-ring; 11,11 X 1,78	27 07 079		

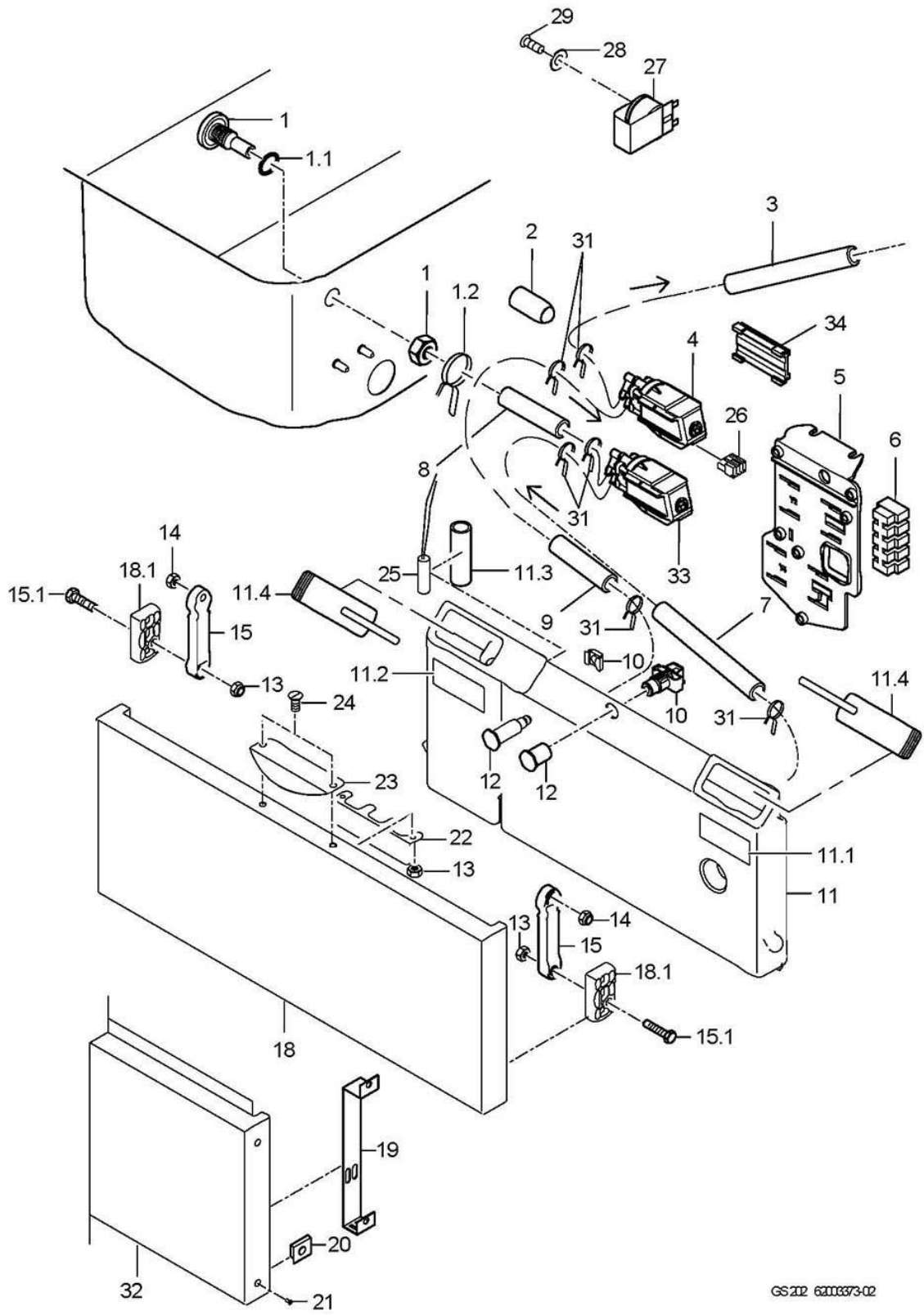

GS 212 6210373-02

GS 202 - GS 402

Dosage

Item.	Designation	Parts no.:	Pc.	Notes
1	Dosing nipple set, M10 X 29; SW5	61005883		
1.1	O-ring; 10 X 2,5	27 07 030		
1.2	Wire hose clamp; D8,6 X 1	28 02 348		
2	End cap; D5,7 X 25,4	35 06 180		
3	Hose; DN5 X 1,5	40 01 024		900 mm; "By-the-metre" goods
4	Fluidos DB "Rinse aid" kit; 115-240V/50-60HZ	31 02 598		
5	Adapter plate; 1,5 X 80 X 100	60003688		
6	Binding post; 5-POLIG; 6QMM; 56,5LG	31 09 230		for connecting external dispenser
7	Hose; DN5 X 1,5	40 01 024		400 mm; "By-the-metre" goods
8	Hose; DN5 X 1,5	40 01 024		300 mm; "By-the-metre" goods
9	Hose; DN5 X 1,5	40 01 024		850 mm; "By-the-metre" goods
10	Captive nut; M8	21 13 006		up to mach. no. 812 260
10	Stud bolt; M8 X 37; M12	60003658		from mach. no. 812 261
11	Detergent container	60003746		
11.1	Label detergent; 0,2 X 28 X 65	60003330		
11.2	Label -Rinse Aid-; 0,2 X 28 X 65	60003310		
11.3	Hose; DN5 X 1,5	40 01 024		50 mm; "By-the-metre" goods
11.4	Cover	60003974		retrofitable; for both sides
12	Magnet support	60003643		up to mach. no. 812 260
12	Magnet support	60003952		from mach. no. 812 261
13	Hexagonal nut; M4 SELBSTSICHERND	21 05 300		
14	Hexagonal nut; M5 SELBSTSICHERND	21 05 302	3	
15	Set of levers	60003778		
15.1	Hexagon screw; M4 X 18	20 01 320		
18	Set of detergent flaps	62003619		with detergent, freshwater rinse dispenser
18.1	Profile; 12,5 X 28 X 50	60003569	2	
19	Bracket; 1,25 X 25 X 243,08	60003823		without detergent, freshwater rinse dispenser; From machine no.: 807 162
20	Sheet metal nut; B 3,9	21 17 301	4	
21	Sheet metal screw; ST 3,9 X 13	20 20 310	4	
22	Elbow; 1,0 X 43 X 100	60003633		
23	Handle kit	60003650		
24	Countersunk screw; M4 X 10	20 12 312		
25	Magnetic switch; 25,5 X D5,75; 2250 LG	31 24 240		
26	Macro-module plug; RAST5;4-POLIG UNCOD.	31 12 094		
27	Buzzer; 230VAC;75DB;23X30,5MM	31 13 133		Additional equipment
27	Set of acoustical level indicators; WPS MAX. VORHANDEN	55 28 281		with max. WPS version
27	Set of acoustical level indicators; WPS MAX.NICHT VORHAND.	55 28 282		with min. WPS version
28	Washer; D5,3 X D15 X 1,2	22 05 301		
29	Raised head screw; M3 X 10	20 10 004		
31	Wire hose clamp; D8,6 X 1	28 02 348		
32	Front panelling, complete	62003553		without detergent, freshwater rinse dispenser; up to mach. no. 807161; order too: 2x60003823
32	Front panelling, complete	62003553		without detergent, freshwater rinse dispenser; From machine no.: 807 162
33	Fluidos DT "Detergent" kit; 115-240V/50-60HZ	31 02 597		
34	Adapter; 11,4 X 33,5 X 57,5	80003775		From machine no.: 1002111
o.P.	Installation kit for detergent dosing device	55 28 279		

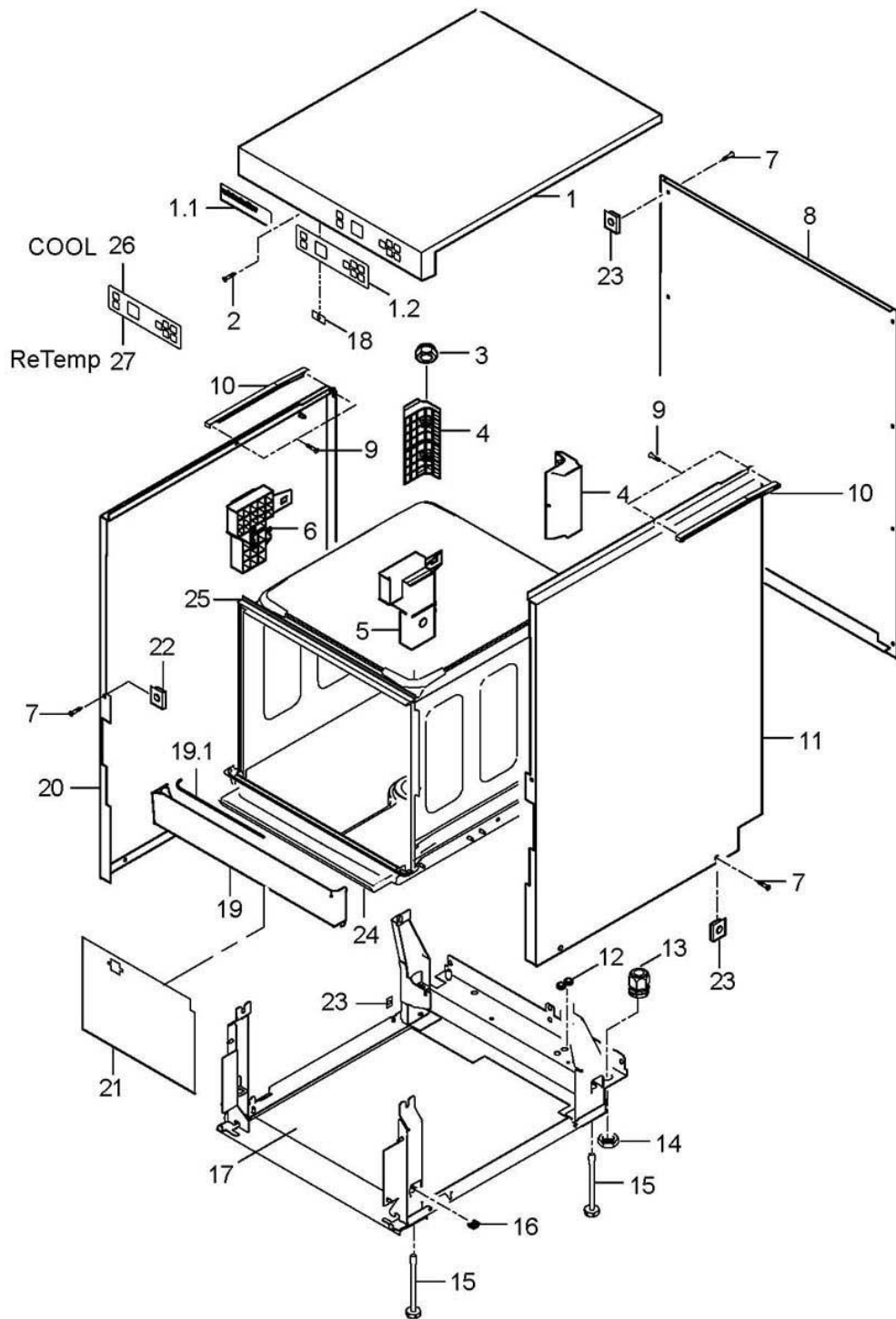

GS212 6200374-01

GS 202 - GS 402

Chassis, container and panelling

Item.	Designation	Parts no.:	Pc.	Notes
1	Cover plate kit	62003349		
1.1	Plate -Winterhalter GS 402-; 0,175 X 30 X 106,8	62003679		
1.1	Plate -Winterhalter GS 202-; 0,175 X 30 X 106,8	62003677		
1.2	Pad -Operating Panel-; 0,175 X 50 X 180	31 24 223		
2	Plate screw; ST 3,9 X 13	20 21 302		
3	Ratchet nut; M5	21 01 310		
4	Support corner rear	60003010	2	
5	Support corner front right	60003009		
6	Support corner left	60003008		
7	Sheet metal screw; ST 3,9 X 13	20 20 310	16	
8	Rear cover	62003546		Plastic
8	Rear cover	62003435		high grade steel; Additional equipment
9	Plate screw; ST 3,9 X 13	20 21 302	2	
10	Slide for cover panel; 250,50 LG	60003501		
11	Housing panel right	62003195		
12	Hose nozzle; 6,25 X D15; D8,5	61004890		
13	Cable gland; M25 X 1,5;9-17MM;IP68	31 10 153		
14	Hexagonal nut; M25 X 1,5 X 6,0; SW32	31 10 163		
15	Adjustable foot; M8 X 129; SW24	60004274	4	
16	Captive nut; M8	21 13 006	4	
17	Bottom plate, complete	62003314		to machine no.: 805 006
17	Base plate; 2,0 X 408,5 X 479	62003501		From machine no.: 805 007
18	Plate nut; B 3,9	21 17 100	2	
19	Screen + Gasket	62003663		
19.1	Sponge rubber cord; D4	40 04 002		540 mm; "By-the-metre" goods
20	Housing panel left compl.	62003194		
21	Protective film; 0,185 X 190 X 240	62003557		retrofitable
22	Sheet metal nut; B 3,9	21 17 304	2	
23	Sheet metal nut; B 3,9	21 17 301	14	
24	Rubber profile; 6,0 X 12 X 570	60003847		adapt
25	Adhesive tape; 9 BREIT;2 DICK X 10000	48 03 022	1	1 roll = 1 m
26	Pad -Operating Panel Cool-; 0,175 X 50 X 180	31 24 269		
27	Pad Operating Panel ReTemp; 0,175 X 50 X 180	31 24 282		
o.P.	Set of vapour protectors, cpl.	80002875		Additional equipment

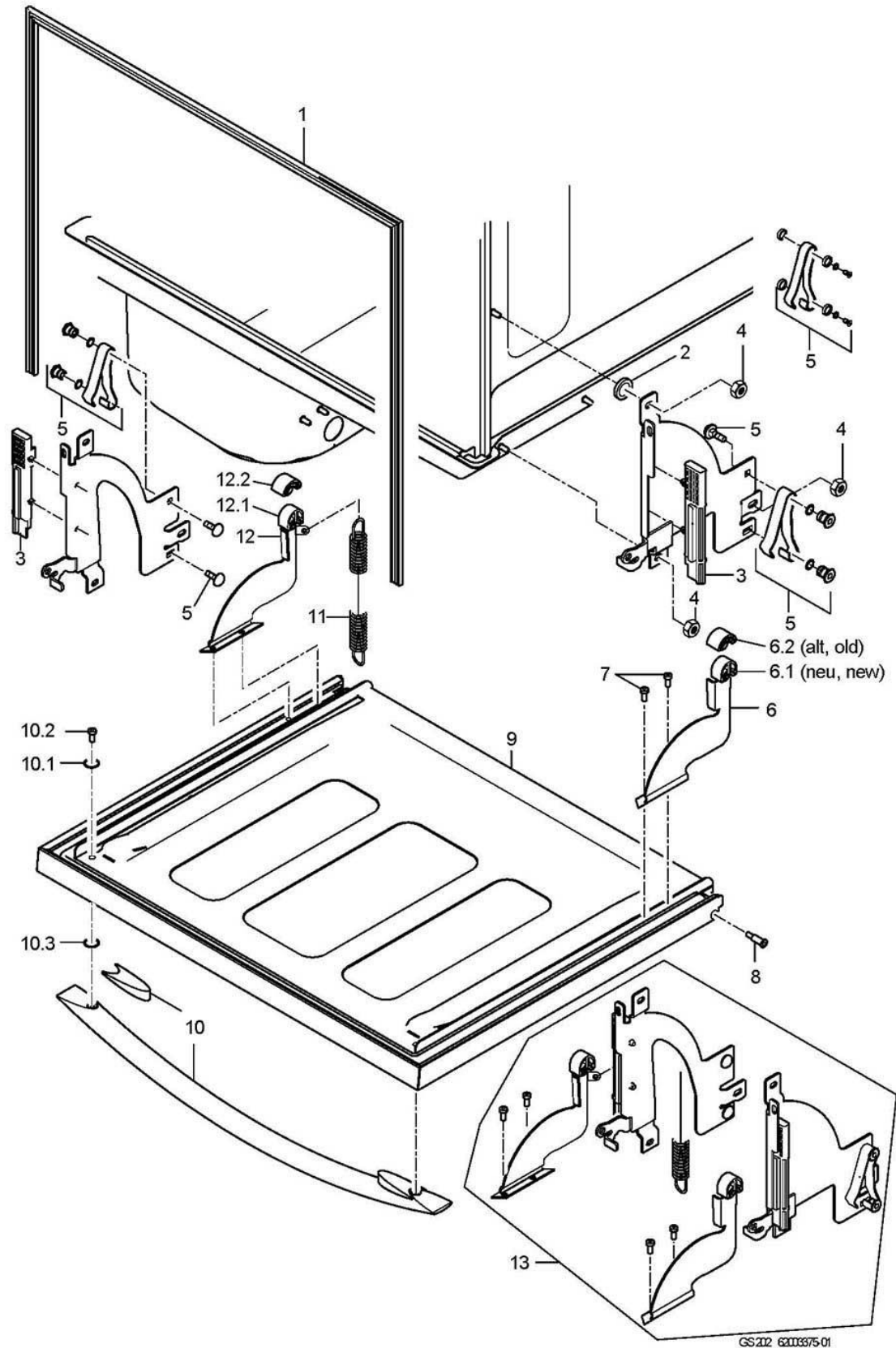

GS212 6210375-01

GS 202 - GS 402

Door

Item.	Designation	Parts no.:	Pc.	Notes
1	Door seal	62003065		
2	Washer; D5,3 X D15 X 1,2	22 05 301		
3	Stopper	62003149		
4	Hexagonal nut; M5 SELBSTSICHERND	21 05 302	3	
5	Leaf spring repair kit	60003743		for both sides; up to mach. no.: 813 023
5	Leaf spring repair kit; 9MM	62003595		for both sides; from mach. no. 813 024
6	Brace right, offset, cpl.	60003995		incl. item 6.1 - 6.2
6.1	Sliding roller	60003870		
6.2	Sliding roller	60003214		
7	Cylindrical screw; M5 X 14,8; SW3	62003334	2	
8	Door bearing bolt; D9 X D7,0 X M5; SW4	60003147	2	
9	Door cpl.	62003572		up to mach. no. 813 023 order too: 62003596
10	Door handle kit	62003350		
10.1	O-ring; 5 X 1,2	27 07 070	2	
10.2	Oval head screw with hexagonal socket; M5 X 30 MIT FLANSCH	20 10 308	2	
10.3	O-ring; 6 X 2	27 07 012	2	
11	Tension spring; L0=193;L1=360,F1=82	60003697	1	
12	Brace left, offset, cpl.	60003994		incl. item 12.1 - 12.2
12.1	Sliding roller	60003870		
12.2	Sliding roller	60003214		
13	Hinge conversion kit 202	62003596		produced in series starting with machine no.: 813 024
o.P.	Silicone adhesive Elastosil E43; 90 ML	34 03 012		for door seals

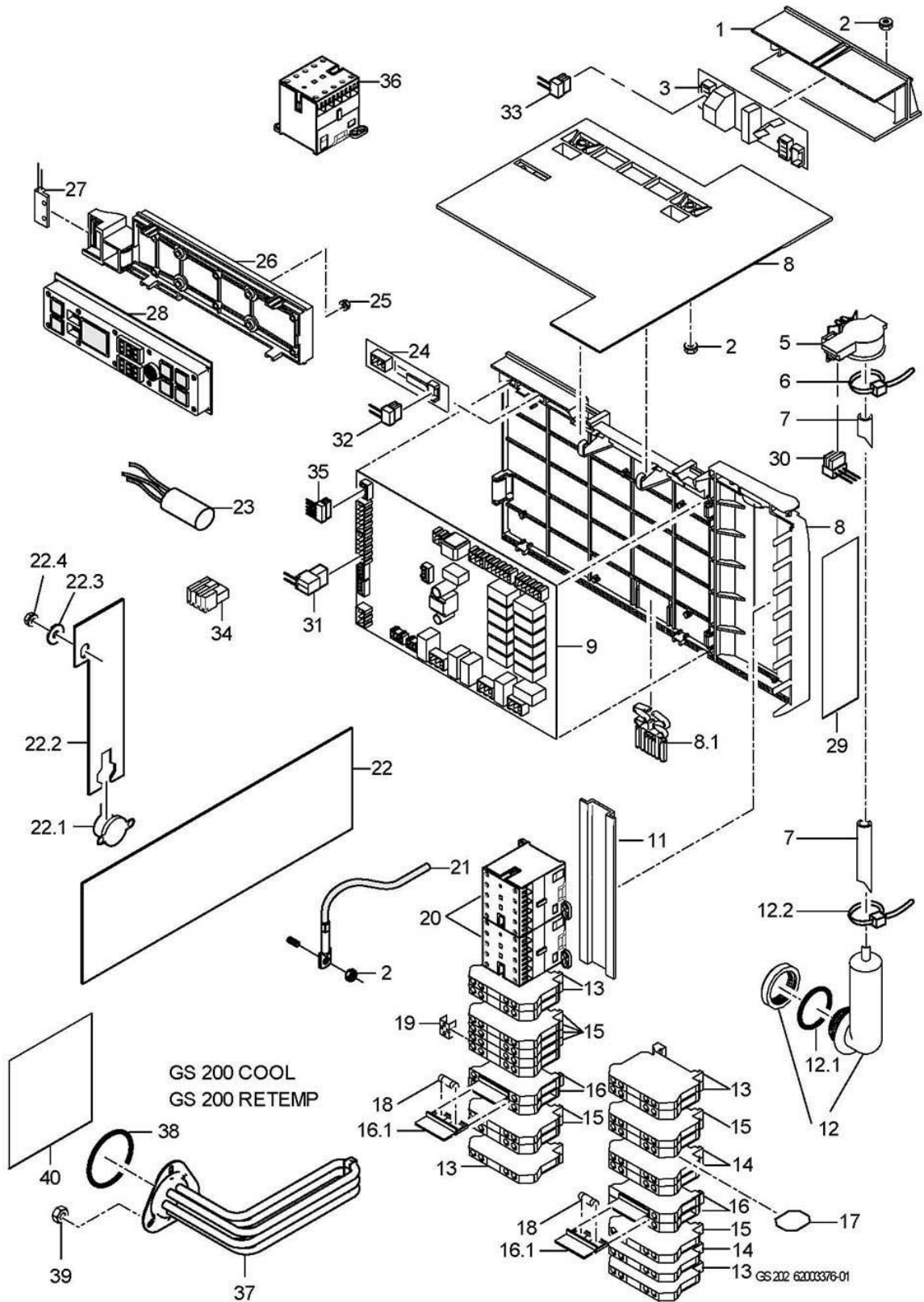

GS 202 - GS 402

Electric parts

Item.	Designation	Parts no.:	Pc.	Notes
1	Protective cover; SCHWARZ	60003541		
2	Ratchet nut; M5	21 01 310	4	
3	Soft start WSA4	31 13 180		
5	Pressure transmitter; 0-30MBAR;5VDC/0,5-3,5V	31 26 044		
6	Cable tie; 100 X 2,5	31 20 175		
7	Hose; DN5 X 1,5	40 01 024		750 mm; "By-the-metre" goods
8	Assembly plate	60003660		incl. item 8.1
8.1	Latch; SCHWARZ	60003356		
9	Programme control WPS MAX Kit; 180-265V; 50/60HZ	31 05 139		
11	Snap-on rail; 1,0 X 35 X 185	60003244		
12	Air chamber set	60003525		
12.1	O-ring	30000196		
12.2	Wire hose clamp; D8,6 X 1	28 02 348		
13	UDK 4-PE double terminal	31 09 153	3	
14	UDK 4 double terminal	31 09 151		
15	UDK 4 BU double terminal	31 09 152		
16	Universal fuse clip	31 09 063	2	
16.1	Securing plug	31 09 072		
17	Isolating disc; 14 X 16	31 09 169		
18	Fine fuse, medium time lag; 250V; 4,0A; 5 X 20	31 11 123	2	has been reduced from 6.3A to 4.0A
19	Fixed bridge; 2-POLIG;	31 09 126		
20	Contacteur B7:3H 1 N/C contact; 220-255V/50-60HZ	31 04 154	2	
20	Contacteur B7:3H 1 N/C contact; 200V/50-60HZ	31 04 171	2	Japan; USA
20	Contacteur B7:3H:1Ö; 208V/50-60HZ	31 04 176	2	
21	Thermal sensor kit 1700mm	80003804		with heat-conducting foil
22	Foil heating element 600 watts; 230V, 310 X 115MM	60003653		
22	Foil heating element 600 watts; 208V, 310 X 115MM	60003654		Japan; USA
22.1	Safety thermostat; 185 GRAD C MAN.RÜCKST.	31 25 053		
22.2	Retainer; 1,0 X 35 X 110,7	60003939		
22.3	Washer; D5,3 X D15 X 1,2	22 05 301		
22.4	Hexagonal nut; M5 SELBSTSICHERND	21 05 302		
23	Radio interference suppression capacitor; 0,27MF + 2 X 27000PF	31 13 078		
24	Level sensor, electronic; 12V; 7MA; 80 X 20 MM	31 13 164		Pressure-independent boiler
25	Nut-and-washer assembly; M3	21 01 312	4	
26	Support for operating panel	60003350		
27	Magnetic switch; 32 X 14,9 X 6,9; 400LG	31 24 229		
28	Operating panel; 25 X 55 X 210	31 24 222		
29	Protective film; 0,185 X 52 X 195	60003764	2	retrofittable
30	Pressure transmitter cable	60003178		
31	Wiring loom; Water softener	60003185		
32	Cable for level sensor; 2 X 0,34QMM	60003175		
33	Wiring loom; Soft start	60003475		

For missing items, see next page

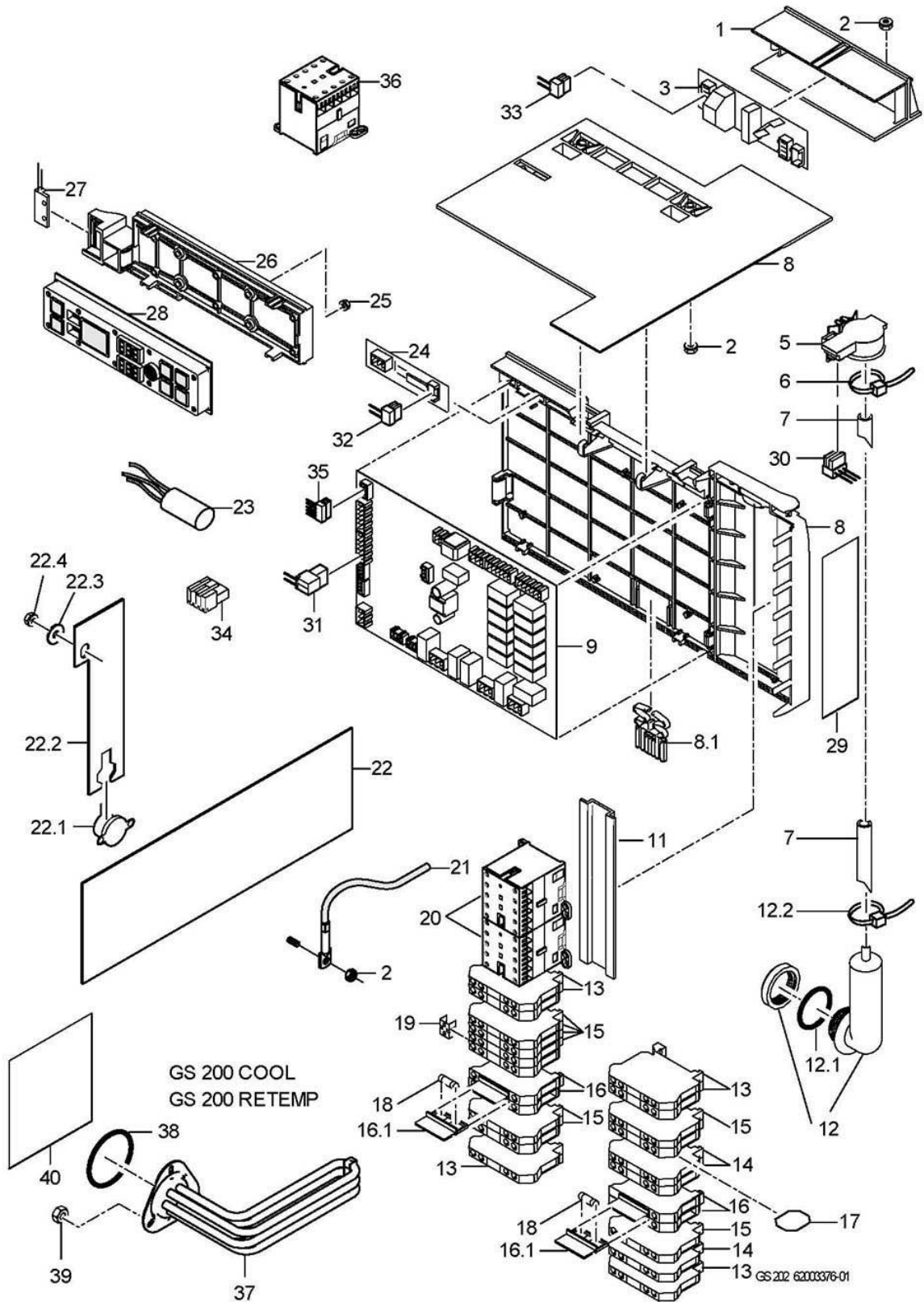

GS 202 - GS 402

Electric parts

Item.	Designation	Parts no.:	Pc.	Notes
34	Macro-module plug; RAST5; 2-POLIG; UNCOD.	31 12 091		
34	Macro-module plug; RAST5;3-POLIG UNCOD.	31 12 093		
34	Macro-module plug; RAST5;4-POLIG UNCOD.	31 12 094		
34	Macro-module plug; RAST2,5;3-POLIG UNCOD.	31 12 095		
34	Macro-module plug; RAST2,5;5-POLIG UNCOD.	31 12 096		
35	Cable bus; 5 X 0,34QMM	60003174		
36	Contacto B7:3H 1 N/C contact; 220-255V/50-60HZ	31 04 154		GS 200 Cool + ReTemp
36	Contacto B7:3H 1 N/C contact; 200V/50-60HZ	31 04 171		GS 200 Cool + ReTemp
37	Heating element 2,6kW; 230V/1	31 03 227		GS 200 Cool + ReTemp
37	Heater with fuse, 5.0kW; 3 X 380-420V	31 03 228		GS 200 Cool + ReTemp
37	Heater with fuse, 5.0kW; 3 X 230V	31 03 230		GS 200 Cool + ReTemp
37	Heater with fuse, 5.0kW; 3 X 200V	31 03 232		GS 200 Cool + ReTemp
38	O-ring; 46 X 6,0	27 07 085		GS 200 Cool + ReTemp
39	Hexagonal nut; M5	21 01 203	3	GS 200 Cool + ReTemp
40	Protective film; 0,31 X 100 X 100	60004267		GS 200 Cool + ReTemp